

HIGH TORQUE HYBRID STEPPING MOTOR SPECIFICATIONS

General specifications		Electrical specifications	
Step Angle (°)	1.8	Rated Voltage (V)	4.2
Temperature Rise (°C)	80 Max (rated current, 2 phase on)	Rated Current (A)	1.5
Ambient Temperature (°C)	-20 ~ +50	Resistance Per Phase ($\pm 10\%$ Ω)	2.8 (25°C)
Number of Phase	2	Inductance Per Phase ($\pm 20\%$ mH)	4.8
Insulation Resistance (M Ω)	100 Min (500VDC)	Holding Torque (N.cm)	55
Insulation Class	Class B		
Max. radial force (N)	28 (20mm from the flange)		
Max. axial force (N)	10		

● Pull out torque curve :

VOLTAGE: 30VAC, CONSTANT CURRENT: 1.5A, HALF STEP

● Wiring Diagram :

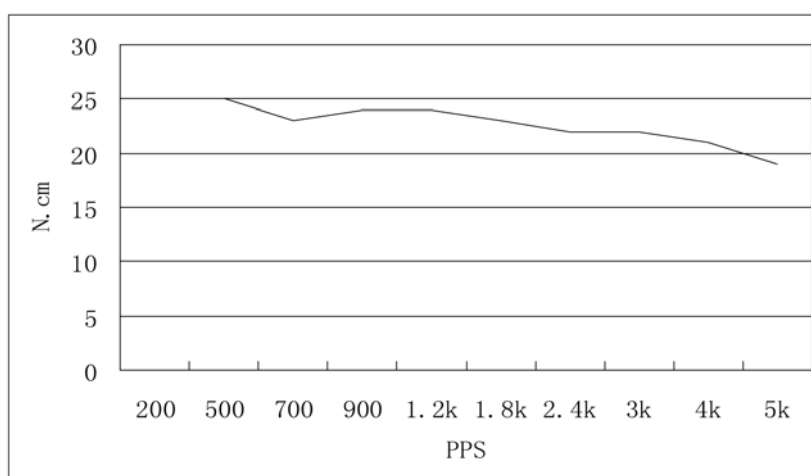
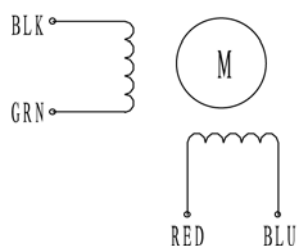

● Dimensions:

(unit=mm)

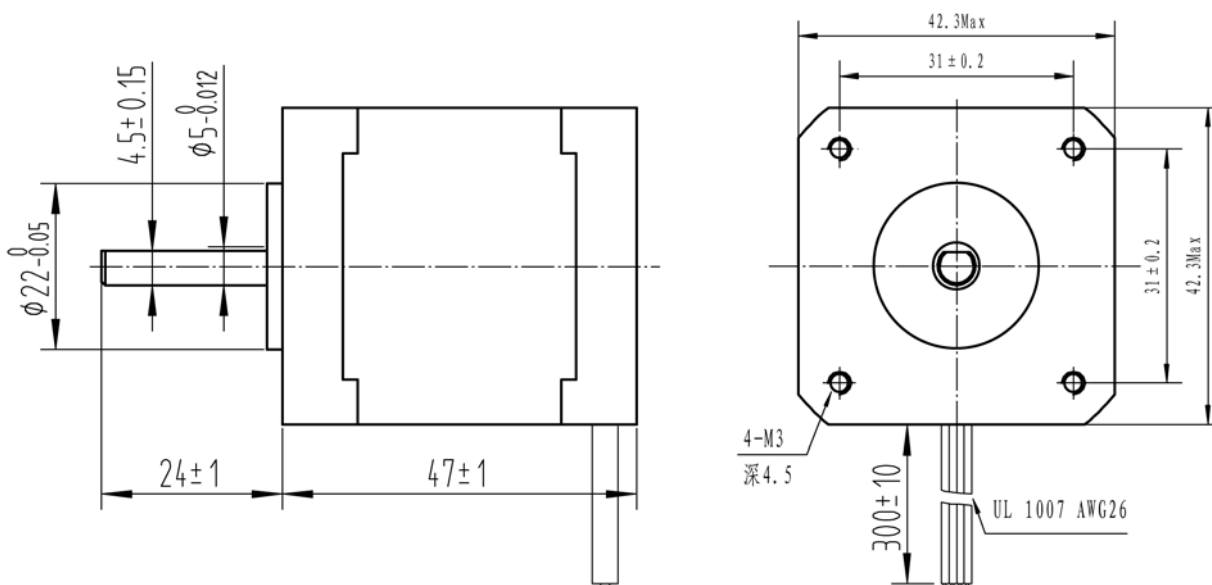

					T42H47-1504	TECHNICAL CONDITIONS
REV	REVISIONS	DESCRIPTION	BY	DATE		
DRAW	2014/02/15					
CHECK						
APPROVE					Tiny Controls	060047117