

HIGH TORQUE HYBRID STEPPING MOTOR SPECIFICATIONS

General specifications		Electrical specifications	
Step Angle (°)	1.8	Rated Voltage (V)	4.65
Temperature Rise (°C)	80 Max (rated current, 2 phase on)	Rated Current (A)	6.2
Ambient Temperature (°C)	-20~+50	Resistance Per Phase ($\pm 10\% \Omega$)	0.75 (25°C)
Number of Phase	2	Inductance Per Phase ($\pm 20\% \text{mH}$)	9
Insulation Resistance (M Ω)	100 Min (500VDC)	Holding Torque (N.m)	12.2
Insulation Class	Class B	Detent Torque (N.m)	0.36
Max.radial force (N)	220 (20mm from the flange)	Rotor Inertia (g. cm ²)	4000
Max.axial force (N)	60	Weight (Kg)	5.39

● Wiring Diagram:

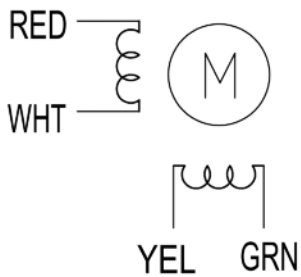

● Pull out torque curve:

VOLTAGE : 110VAC, CONSTANT CURRENT: 6.2A, HALF STEP

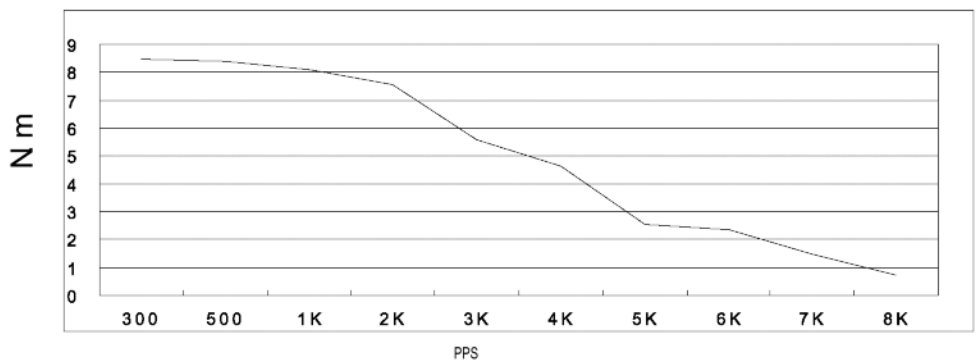

● Dimensions:
(unit=mm)

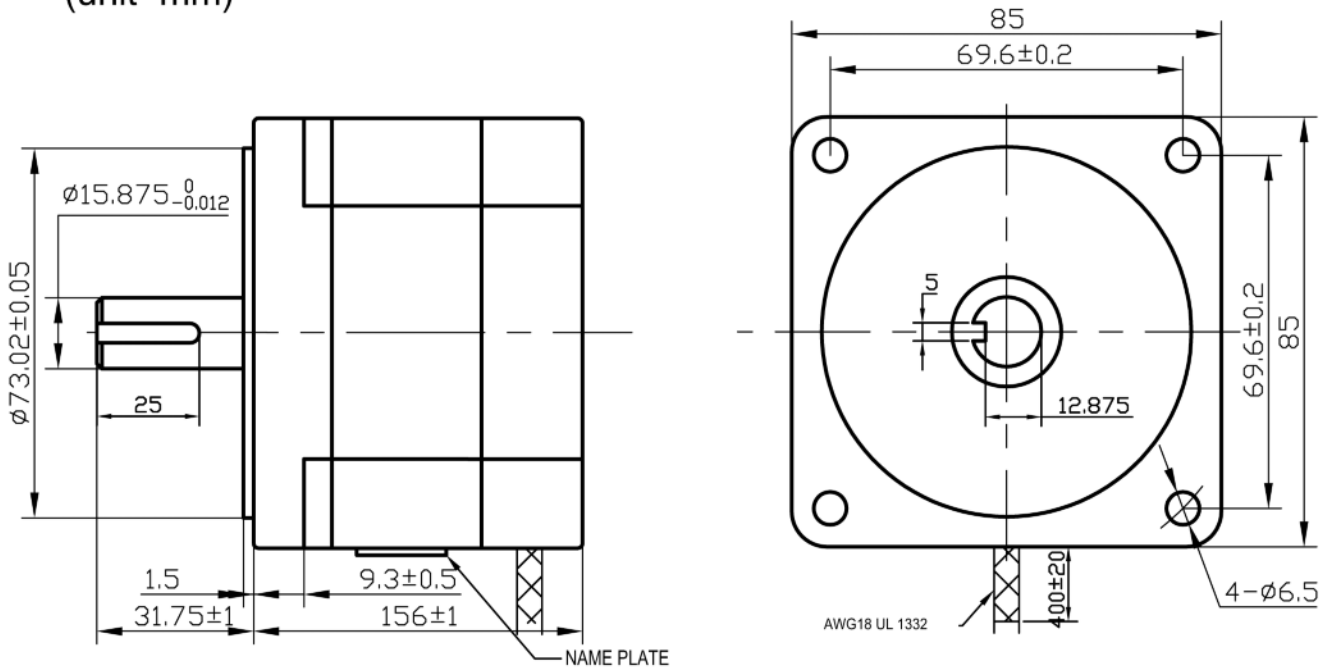

△					T85H156-6204	TECHNICAL CONDITIONS
△						
REV	REVISIONS	DESCRIPTION	BY	DATE	Tiny Controls	110156000
DRAW	2012/4/27					
CHECK						
APPROVE						